

Papaer Telkomnika

by Kurriawan Pranata

Submission date: 22-Jan-2021 07:39AM (UTC+0700)

Submission ID: 1491835295

File name: 1570676884_Final_21012020_untuk_turnitin..doc (1.21M)

Word count: 3744

Character count: 18836

Experimental Study of The Capacity and Electrode Structure on Six Cell Dynamic Lead Acid Battery

Kurriawan Budi Pranata¹, Yuni Triasari², Nur Khairati³, Istiroyah⁴ Mauludi Ariesto Pamungkas⁵,
Muhammad Ghufron^{6*},

¹Physics Education Study Program, Universitas Kanjuruhan Malang, Malang, Indonesia

^{2,3}Graduated Student, Department of Physics, Faculty of Mathematics and Natural Science, University of Brawijaya, Malang 65145, Indonesia

^{4,5,6}Department of Physics, Faculty of Mathematic and Natural Science, University of Brawijaya, Malang, Indonesia

Article Info

Keywords:

Dynamic Lead Acid Battery
Discharging Current
Capacity Efficiency
Anglesite
Plattnerite

ABSTRACT

The six cells of the Dynamic Lead Acid Battery (DLAB) series have been made to resemble the accumulator with sulfuric acid single electrolyte. The tank was fill with 1200 mL of 30% sulfuric acid and circulated through each unit cell by a minipump during charge-discharge process. Experiments were carried out by providing a charging current of 2A, while the discharge current was varied at 0.5 A, 0.6 A, 0.7 A, 0.8 A for 10 continuous cycle to find out the battery with the best characteristics. All batteries have a working voltage at 10.8-14.4 volt during test. The discharging current is inversely proportional to the discharging duration. The resulting capacity has an efficiency ranging from 80.1-81.1%. DLAB with 0.5 A discharging current shows the best performance based on the length of duration and the average capacity with value of 109.61 h and 6168 mAh while for the ideal performance stability is obtained by DLAB with 0.7 A discharging current. The electrochemical reaction produces anglesite and plattnerite phases on the positive electrode. Meanwhile, anglesite and lead phases are formed on the negative electrode.



1. INTRODUCTION

There are still many areas in Indonesia that do not yet have the access to electricity on a regular basis such as Papua and Nusa Tenggara Timur [1]. In fact, the Ministry of Energy and Mineral Resources (ESDM) noted that the province of Nusa Tenggara Timur (NTT) and Papua were priority targets for the Energy Saving Solar Light Program (LTSHE) in 2019. The ESDM plans to increase the electrification ratio through the Solar Energy Saving Lighting Program (LTSHE) installation program of 20,934 units for Nusa NTT province and 13,320 units for Papua province. This means that there are still 20.934 villages in NTT province and 13.320 villages in Papua province that have no access to electricity [2]. The government plans to increase the electrofication ratio, including the use of renewable energy such as wind energy and solar cells. Renewable energy requires electrical energy storage during their utilization which makes the demand for electrical energy storage will increase in the future. One of the alternatives that can be used is Dynamic Lead Acid Battery (DLAB) because it is inexpensive, easy to install, generates high density energy and has long-lasting charge-discharge life-cycle characteristics [3]. DLAB is the single flow battery with two electrodes, namely Pb as negative electrode and PbO₂ as positive electrode and a pump to circulate H₂SO₄

electrolyte from reservoir to each unit cell [4]. The choice of using Pb/PbO₂ as electrodes is based on a research by Gaston Planté which conducted polarization comparisons between various types of electrodes [5], [6].

The result shows that Pb and PbO₂ electrodes with sulfuric acid as electrolyte manifest the highest voltage with the longest battery life [7]. In addition, DLAB is relatively easy to manufacture and affordable. It is available commercially in various sizes so it is easy to adjust and has rapid development in respond to the advancement of large scale energy storage [8]. This battery can also face excessive charging and has a low self-discharge [2] compared to other batteries [9]. The majority of previous studies confirm that DLAB is very promising for future applications in large-scale manufacturing [10] such as battery for solar cell fields. Comparison of the performance of Dynamic and Static lead Acid Battery single cell with electrolyte methane sulfonic acid [4], [11] and sulfuric acid [12], [13] shows that dynamic batteries have better performance than the static batteries. Membrane separator [14], current density [15], long life cycle [16], electrode deposition [17] in dynamic lead acid battery has been observed by many researchers but limited to single cell battery while publication in bipolar cells infrequently found [18]. The reports of DLAB with more than 3 cells are rarely seen, so this research tries to manufacture six cell Dynamic Lead Acid Battery system and analyse the characteristic of the battery through charge-discharge test using Turnigy as Battery Management System (BMS). Various discharging currents were applied to the battery system to find out the best battery. The phase transformation occurs on the two electrodes is also reported in this study by using XRD apparatus.

2. RESEARCH METHOD

Figure 1 (a) Shows five parts in the six-cell dynamic lead acid battery research, consist of : construction of electrolyte reservoir, construction of six units of cell container, installation of peristaltic pump system, electrolyte flow setting, installation of electrode arrangement. The battery test consists of two parts consisting of a cycle test to obtain ten cycles of charge-discharge data and a microstructure test to obtain XRD pattern data.

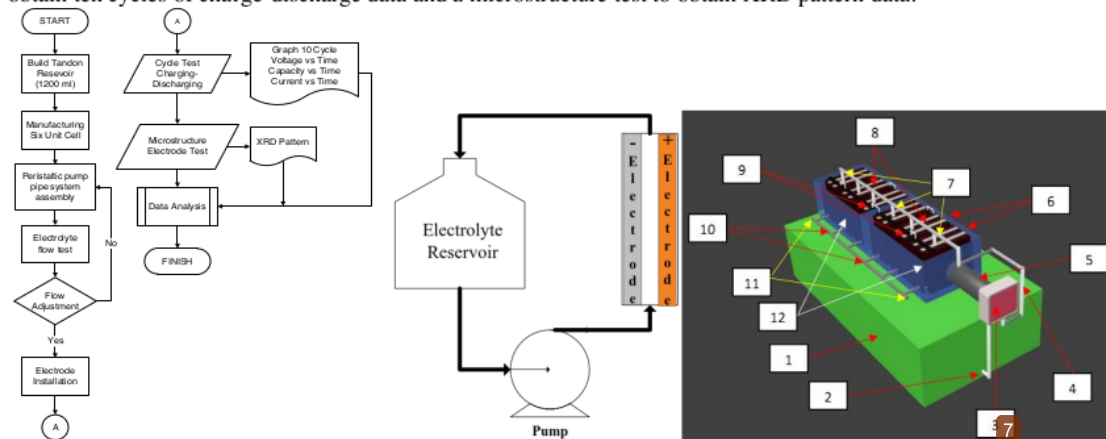

Figure 1. (a) Flow chart of the research of DLAB (b) Concept design standardizations of a single soluble lead flow cell (c) Design of six-cell dynamic lead acid battery array in the experiment

Figure 1 (b), the battery made in this study refers to the standard battery in Krishna's [3], [14], [19] and Zhang [4] where a battery system consists of Pb and PbO electrodes separated by 2 mm, with an area of 24 cm² for each electrodes. A low voltage peristaltic pump is used to circulate the 30% H₂O₄ electrolyte around the system. A redox reaction occurs during charging where the positive ion Pb²⁺ returns to solid Pb at the negative electrode and PbO₂ on the positive electrode. This design has advantages compare to the other systems which only a single electrolyte is used with two solid deposition reactions, on positive and negative electrodes. So it will eliminate cross-contamination of electrolyte and there is no electrolyte separator such as ion-exchange membrane or microporous film needed which make it more simple and cheaper [20]. Figure 1 (c), which in this study is referred as Dynamic Lead Acid Battery (DLAB) with six cell units. Figure 1 (c), shows DLAB design in this experiment and the explanation can be seen in Table 1.

Three holes with a diameter of 3 mm were made in each cell with the functions of one inlet, one outlet and one drain. The battery pack then connected to Turnigy 80 Watt Accucell-6, peristaltic pump, computer with ChargeMaster2 application and an electrolyte tank that has been filled with 1000 ml of 30% H₂SO₄. Battery capacity shows the amount of electric charge that can be released by the battery. The large amount of the electric charge

depends on the concentration of H_2SO_4 , higher H_2SO_4 concentration leads to longer discharge time which means there will be longer time to release the charge. Battery discharge time is proportional to battery capacity, so the length of time for discharging the battery identifies the value of the capacity of a battery.

Table 1. The Explanation of the six-cell dynamic lead acid battery design in Figure 1 (c)

Description of Figure 1 (c)	Explanation
1	1200 ml volume electrolyte tank containing 1000 ml H_2SO_4 with concentration of 30%
2	Electrolyte solution from the tank is flowed out the suction pipe No. 2 by a peristaltic pump
3	Peristaltic pump
4	The liquid electrolyte is circulated by peristaltic pump through pipe No. 4 to each battery cell unit
5	Peristaltic pump cantilever
6	The back of the upper side of each cell unit is given a drain control hole when the solution overflows the cell unit.
7	Each branching pipe is equipped with a stop valve to control the rate of electrolytes entering each battery cell unit
8	Location of: positive electrode membrane negative electrode
9	Copper conector cable is used to assemble the positive electrode and negative electrode series configuration
10	Each unit cell has an electrolyte outlet through a branching pipe with a stop valve.
11	all branching points bore to two holes to the electrolyte reservoir
12	The total size of six cell units is 300 ml, with each cell unit contains 50 ml of electrolyte.

A previous research, where various concentrations of H_2SO_4 solution with ranges from 20%, 30% and 40% were used for a single cell DLAB system, shows that the average capacity of dynamic lead acid batteries has increased along with the increase of H_2SO_4 concentration. Meanwhile, when H_2SO_4 with concentration higher than 40%, namely at a concentration of 50%, the average dynamic battery capacity decreased. This study shows that the concentrations of 30% and 40% are the most ideal concentrations for the single cell DLAB system [13]. From the cycle test, graphs of voltage, current and capacity of the batteries are obtained and displayed by the ChargeMaster2. WebplotDigitizer and Microsoft Excel are used to analyze the graphs. This study shows the variation of the abbreviated parameters for each 2A charging current test and the different discharge currents of 0.5 A (BD5), 0.6 A (BD6), 0.7 A (BD7), 0.8 A (BD8) for each battery used in this article. This XRD test used *bulk* or *powder* from the grinding of Pb and PbO electrodes after the cyclic process was completed. The results of grinding then ground into a fine powder which was then tested with PANalytical X'pert Powder. The angle used was a short angle of 20 to 70 degrees with the X-ray wavelength of the XRD device. It was 1.544 Å for K-Alpha1, 1.541 Å for K-Alpha2, and 1.392 Å for K-Beta. To make the sample can be irradiated with X-rays evenly, a spin holder was used. After being tested, raw data were obtained then were checked with the Match!3 application to find out the micro structure changes of each electrode. The change sought in this study was the change in the phase and composition of the battery electrodes by matching (search match) the number of equal peaks between the sample and the Match3! Database.

3. RESULTS AND ANALYSIS

3.1 Initial Discharging and Variation of Discharging

Before examining the characteristics of the lead acid dynamic battery, the BD5 battery is discharged with a discharge current of 0.5 A. All of the batteries should be discharged before the charge-discharge test is carried out. The result of this initial discharging capacity produced by each battery can be seen in the Figure 2 (a).

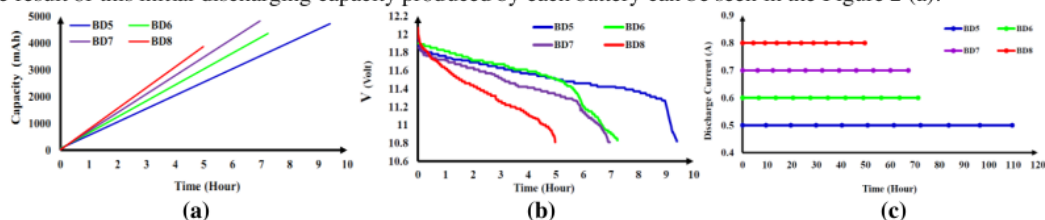

Figure 2. (a) DLAB capacity performance (b) Voltage of DLAB as a function of time during initial discharge (c) The discharge duration comparison of (DLAB) with a variation of discharge current

After doing the initial discharge, it is known the amount of capacity and voltage generated from each battery. The capacity of the battery tends to decrease with the increasing of applied discharged current. Table 2. below shows the detail of data for the initial discharge of the four batteries.

Table 2. Voltage, capacity and discharging duration of DLAB initial discharge

Bateray	Voltage (V)		Capaity (mAh)	Time (Hour)
	Start	End		
BD5	11.98	10.81	4727	9.40
BD6	11.90	10.83	4363	7.23
BD7	11.85	10.81	4828	6.95
BD8	12.07	10.81	3870	4.98

Table 2, it can be seen that the battery tends to have smaller voltage when it is given a larger current. One thing that affects the initial voltage is the applied current, based on equation 1:

$$V = E - Ir \dots (1)$$

where V is the voltage measured, ε is the battery emf, I is the current and R is the resistance. If the given current is large, the reduction from IR will be greater so the voltage obtained will be smaller. Initial voltage of BD8 is the highest voltage of each battery which can be caused by an energy surge on the beginning of the discharging process. Based on Figure 2 (b), the final voltage of each battery is constant at 10.8 volts. At this voltage, the discharge process is stopped and the redox reaction in the discharge process has ended. This is due to the Turnigy setting which has been set to a final voltage value of 1.8 volts per cell to prevent an overdischarge which can damage the battery faster.

The voltage in the process of charging a battery increased and stopped at 14.4 volts. The increasing voltage indicates that there is a process of storing electricity in all four batteries. The set value of current for the charging process is 2 A. During the charging process, the battery current is constant at 2 A. At the final stage of the charging process, the charging current decreases until the minimum value of current at 0.09 A and the voltage of the battery will be constant at 14.4 V during this stage. In the previous research, the battery charging process ends when the minimum current is reached, where there is no more charge stored in the battery. During discharging, the battery voltage decreases from the rated open voltage to the initial discharge voltage due to the internal resistance of the battery. The battery voltage then decreases slowly, indicating that the battery is releasing the stored energy, the smaller the load current applied the longer the time spent in discharging the battery charge [21]. This theory is proven in this study where BD5 has the longest time of 109.61 hours, followed by BD6, BD7 and BD8 with respective durations of 71.92 hours, 68.59 hours and 49.69 hours as shown in Figure 2 (c).

3.3 Battery Capacity

Battery capacity is recorded for the 10 cycles of charging-discharging test with a constant current method. The electric current used for charging is the same value of 2 A for all variations of battery tested. For discharging, the electric current variation used are 0.5 A for BD5, 0.6 A for BD6, 0.7 A for BD7 and 0.8 A for BD8. Figure 4 shows that the four types of batteries provide relatively similar graph patterns, but the time needed for each battery to complete each charge-discharge process during the 10 cycles test is different. BD5 takes 180.14 hours to complete the 10 cycles, BD6 takes 127.54 hours, BD7 takes 131.99. hours and BD8 takes 91.45 hours. Based on the time of 10 cycles, BD5 certainly shows a longer battery life cycle because BD5 has been loaded with a discharge current value of 0.5 A which is the smallest value among the other variations of discharge current. Based on the capacity and charge-discharge time, BD5 has the best performance since it has longer life-cycle and the greatest capacity compare to the other batteries.

Figure 4 shows that during the 10 cycles, the fluctuation of the capacity occurs with a downward trend, this result is similar to a previous research [22]. Figure 4 (a) the charging capacity produced by BD5 batteries is in the range of 6100 mAh to less than 8400 mAh. Figure 4 (b) BD6 has charging capacity in the range of 5002-6533 mAh. Figure 4 (c) BD7 is in the range of 5505-6192 mAh and Figure 4 (d) BD8 is in the range of 4257-5935 mAh. It is shown that BD5 has a decreasing trend of charging capacity, while the other batteries have fluctuating charging capacity. All battery also shows that the discharging capacity is fluctuating for BD5, BD7 and BD8. The 3 batteries

have discharging capacity in the range of 4800-6603 mAh, 4320-5046 mAh and 3560-4591 mAh respectively. Meanwhile, BD6 has discharging capacity in the range of 4033-4557 mAh. Although BD6 does not show the greatest range of capacity, the capacity tends to be more constant compare to the other batteries.

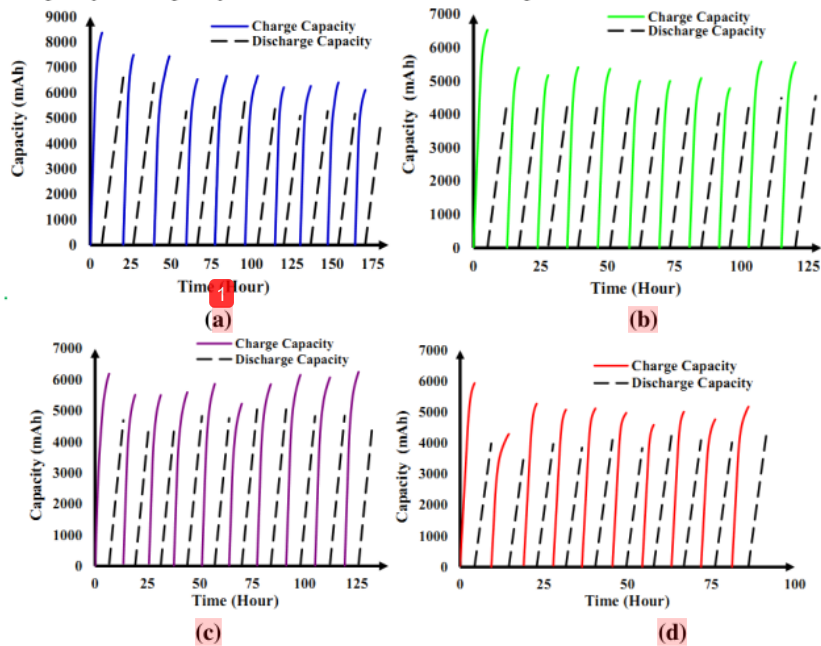

Figure 4. The capacity-time graph of 10 charge-discharge cycles produced by batteries (a) BD5, (b) BD6, (c) BD7 and (d) BD8

Compared to the other batteries, BD8 has the shortest time to complete the ten cycles. This can be caused by the discharge current used, which is the largest discharge current of 0.8 A. So that the discharge process finish earlier than the others. From Figure 4 it can be seen that the capacity produced by the discharge process is lower than the charging capacity. This is because the use of different charging and discharging currents will affect the amount of charge per second.

3.4 Capacity Efficiency

The four variation of DLAB shows a good result where they all have capacity efficiency values above 50%. The capacity efficiency values is by by calculating the ratio of discharge capacity to charge capacity or it can also be calculated by dividing the value of discharge time by the charge time referred to the study in [23], [24], [10]. In this study, the calculation of the capacity efficiency value uses the comparison of the value of the discharge to charge capacity. Figure 5, the highest efficiency of 81.1% is produced by BD5, then followed by BD6, BD7 and the smallest is BD8 with values of 81.0%, 80.7% and 80.1% respectively. From Figure 5, it can be concluded that the smaller the current used, the more capacity is generated in a longer period, resulting greater efficiency.

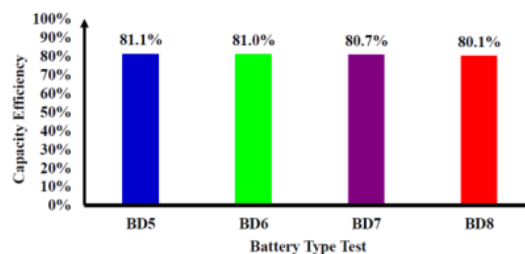

Figure 5. Comparison of capacity efficiency among six cell lead acid dynamic batteries

3.5 Comparison of DLAB with commercial lead acid batteries

Based on previous research, lead acid secondary battery technology is a mature technology that can be used nation wide in a variety of renewable energy storage applications [25]. Although lead acid batteries have mature technology and are affordable in price, lead acid batteries are sensitive to misuse such as ambient temperature ranges, lifetime [4], charging methods [25], and stationary energy storage problems [26]. The same conditions also happen in lead acid dynamic battery. Table 3 shows and comparison of the dynamic lead acid battery used in this study with a commercial lead acid battery.

Table 3. Comparison of DLAB, Lead Acid and Soluble Lead Flow battery.

Tecnology	DLAB	Lead Acid	Soluble Lead Flow Battery
Cell voltage, V	2.05 [27]	2.0 [28]	1.78 [29]
Capacity Efficiency, %	91-94 [27]	75-100 [28]	50-85 [30]
Voltage Efficiency, %	86-88 [27]	88-89 [21]	60-70 [14]
Energy Efficiency, %	83 [31]	45 [20]	52-74 [9]
Temperature range, °C	25-40 [4]	20–25 [25]	35-55 [25]

Table 3 shows that the performance comparison between commercial lead acid battery and soluble lead flow batteries as referred to the previous research. Each battery has its own advantages and disadvantages. The DLAB has a higher cell voltage than other compared batteries. DLAB has a comparable energy efficiency range to commercial batteries, is low cost and simple with no ion exchange membrane needed in the battery.

3.6 Micro Electrode Structure

The XRD test of the negative electrode fines can be seen on Figure 6 (a) where pattern of peaks is found as the indication of crystal structure on the electrode. Litherage phase (JCPDS No. 96-901-2702) and lead phase (JCPDS No. 96-900-8478) are found on the negative electrode before the charge-discharge cycle test is carried out (BD0). The phase transform into Anglesite phase (JCPDS No. 96-901-2702) after the charge-discharge cycle test is carried out [32]–[34].

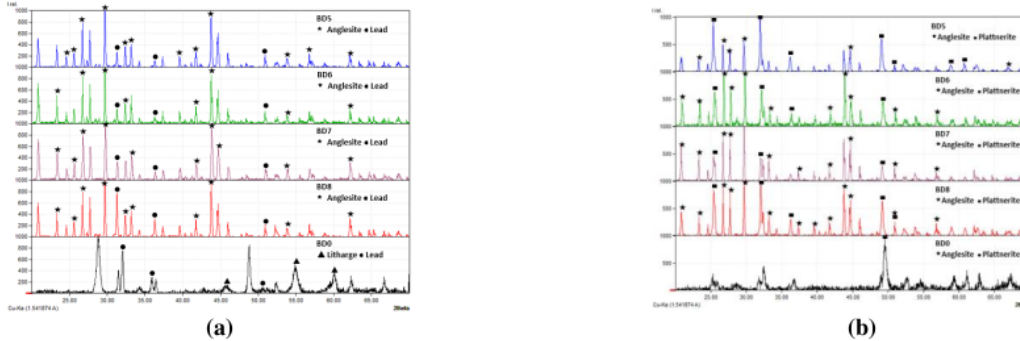

Figure 6. Micro structure of BD5, BD6, BD7, BD8 and BD0 (a) Negative electrode (b) Positive electrode
 This shows that redox reaction occurs in the battery during the process of charge-discharge test. Table 4, it is known that anglesite phase dominates the negative electrode. After the discharge process, the lead (Pb) phase is oxidised and forms the anglesite (PbSO₄) phase with percentage more than 88.4% after 10 charge-discharge cycles [35], [36].



Table 4. The percentage of negative electrodes of BD5, BD6, BD7, BD8 and BD0

Negative electrode	Anglesite (%)	Lead (%)	Positive electrode	Anglesite (%)	Plattnerite (%)
BD5	95.8	4.2	BD5	60.6	39.4
BD6	95.1	4.9	BD6	76.0	24.0
BD7	94.7	5.3	BD7	86.6	13.4
BD8	88.4	11.6	BD8	75.8	24.2
BD0	-	-	BD0	-	7.6

Based on Table 4, a lower load current value causes more formation of anglesite phase. This is because a lower load current produce longer discharge duration so that there will be more redox reaction occurs and the

amount of anglesite deposit as the result of the reaction is greater. The small amount of lead phase shown in Table 6 is caused by the deposit of anglesite phase on the surface of the electrode. After some period of time, the anglesite will cover all of the surface of the electrode and become barrier and there will be no redox reaction occur between the electrolyte and the layer of lead under the anglesite deposit [37], [38]. Figure 6 (b) shows the XRD graph of the positive electrode after 10 charge-discharge cycles. It shows that anglesite and plattnerite phases are found on the electrodes. The anglesite (PbSO_4) phase occurs as a result of Pb ion reduction with a larger amount than the plattnerite phase. A trend of an increasing of anglesite phase can be seen on Table 4 where a larger load current leads to a larger amount of formed anglesite phase which is followed by a decreasing of the amount of plattnerite phase.

4. CONCLUSION

Six cells Dynamic Lead Acid Battery (DLAB) with Pb and PbO_2 electrodes have been successfully made and examined with charging current of 2 and variations of the discharge current of 0.5 A, 0.6 A, 0.7 A and 0.8 A for 10 charge-discharge cycles. The longest life cycle and highest capacity value is obtained by BD5 battery. However, for the ideal performance stability is obtained by BD7. So, it can be ascertained that DLAB works effectively in the discharging current of 0.7 A. The results of the DLAB capacity test shows that the value of battery capacity for BD5, BD6, BD7, BD8 are fluctuative with capacity in the range of value of 4512 mAh-6168 mAh. This result is supported by the calculation of the capacity efficiency of the four types of batteries which show similar values with the range of 80.1-81.1%. This means that the range of estimated errors to handle DLAB's capacity is very small. On a charge-discharge test, the anglesite phase change occurs in the electrodes structure tends to increase for the positive electrode and decreasing for the negative electrode when a higher charge discharge current is applied. In the future, this research work will be developed regarding the analysis of the treatment performance of more charge discharge cycles, greater variations in charge-discharge current and variations in flow rates of electrolyte.

ORIGINALITY REPORT

7%

SIMILARITY INDEX

2%

INTERNET SOURCES

6%

PUBLICATIONS

2%

STUDENT PAPERS

PRIMARY SOURCES

- 1 M Ghufron, Istiroyah, C A Perwita, Masruroh, N Khairati, F R Ramadhan, Y E Setiawan, K B Pranata. "Influence of electrolyte concentration on static and dynamic Lead-Acid battery", *Journal of Physics: Conference Series*, 2020
Publication 3%
- 2 C.P. Zhang, S.M. Sharkh, X. Li, F.C. Walsh, C.N. Zhang, J.C. Jiang. "The performance of a soluble lead-acid flow battery and its comparison to a static lead-acid battery", *Energy Conversion and Management*, 2011
Publication 1%
- 3 Submitted to Universitas Airlangga
Student Paper 1%
- 4 Dapeng Zhang, Qinghua Liu, Yongdan Li. "Design of flow battery", Elsevier BV, 2014
Publication <1%
- 5 Irrd.org
Internet Source <1%

6

Vincenzo Fracastoro. "Tecno-economic assessment of an off-grid PV-powered community kitchen for developing regions", *Applied Energy*, 2012

Publication

<1%

7

M. Krishna, E.J. Fraser, R.G.A. Wills, F.C. Walsh. "Developments in soluble lead flow batteries and remaining challenges: An illustrated review", *Journal of Energy Storage*, 2018

Publication

<1%

8

A. Oury, A. Kirchev, Y. Bultel. "Cycling of soluble lead flow cells comprising a honeycomb-shaped positive electrode", *Journal of Power Sources*, 2014

Publication

<1%

9

R.G.A. Wills, D. Pletcher, F.C. Walsh. "Flow Batteries", Elsevier BV, 2015

Publication

<1%

Exclude quotes Off

Exclude matches Off

Exclude bibliography On